

OPERATION MANUAL

<OM-C25G-2CU>

MODEL ULC-25G
SINGLE-PHASE 110V.200~240V

This operation manual describes only matters related to the operator.
As for handling in a whole shutter system, please refer to instructions given by the shutter manufacturer.

① ATTENTION OF SECURITY

There are 'WARNING' and 'CAUTION' to be separated by degree of harm and damage.

WARNING: If the system is wrongly set up or handled, death or serious injury may result.

- (1) In positioning the motor-driven operator properly, carefully read the catalogue.
- (2) The shutter operator is specifically designed for motor-driven shutters. Never use the shutter operator for any other applications.
- (3) Setting up the shutter operator includes works to be done by a well-skilled, qualified electrician. Only such qualified person shall install the shutter operator.
 - Otherwise the operator may not work normally, and the shutter may damage, then an injury may result.
- (4) Please use our exclusive bracket.
 - Otherwise the operator may not work normally, and an injury may result by damaged shutter as the case may be.
- (5) Firmly fix bracket in a suitable position on the structural members, referring to the shutter layout (installation drawing).
 - As the both brackets bear all shutter weight, an injury may result by damaged shutter if it is not tightly fixed.
- (6) Install the shutter operator in a place not exposed to rain and any other water.
 - Otherwise a fire or an electrical shock may result.
- (7) Be sure to ground the shutter operator.
 - Otherwise a fire or an electrical shock may result.
- (8) Do not disassemble nor tamper with the shutter operator. Nor attach any extra components than our specified options.
 - Otherwise an injury may result by abnormal operation.
- (9) Before opening and closing the shutter, make sure there is nobody and no obstacle around.

Be sure to instruct the person in charge of the shutter operator to keep this in mind.

 - Otherwise an injury may result by being caught in the shutter.
- (10) Choose key-locked push button switches.
 - Otherwise an injury may result by being caught in the shutter if any other person being not in charge, e.g. a child, operates.

CAUTION: If the system is wrongly set up or handled, personal injury or property damage may result.

- (1) Be sure to keep the supply voltage within the shutter operator's specified range.
 - Otherwise the operator may damage, and then it may cause a fire or an electrical shock.
- (2) Make sure the shutter's weight and size are below the door's applicable ratings.
 - Otherwise the operator may not work normally, and the shutter may damage, then an injury may result.
- (3) Before using the manual short-link handchain, make sure the shutter is not moving. Never use the push button switches.

Be sure to instruct the person in charge of the shutter operator to keep this in mind.

 - Otherwise the manual short-link handchain will be pulled into the operator, then the operator may result in damage.
- (4) Before using the gravity fall lever, make sure the shutter is not moving. Never use the push button switches.

Be sure to instruct the person in charge of the shutter operator to keep this in mind.

 - Otherwise the operator may not work normally, then the shutter may damage.
- (5) Make proper limit switch settings. And be sure to check the stop position.
- (6) Inspect the shutter operator periodically. If anything unusual is found, repair or replace. For periodic checks, keep the number of times or period for inspection given in the INSPECTION clause on this operation manual.

② PARTS DETAILS OF OPERATOR

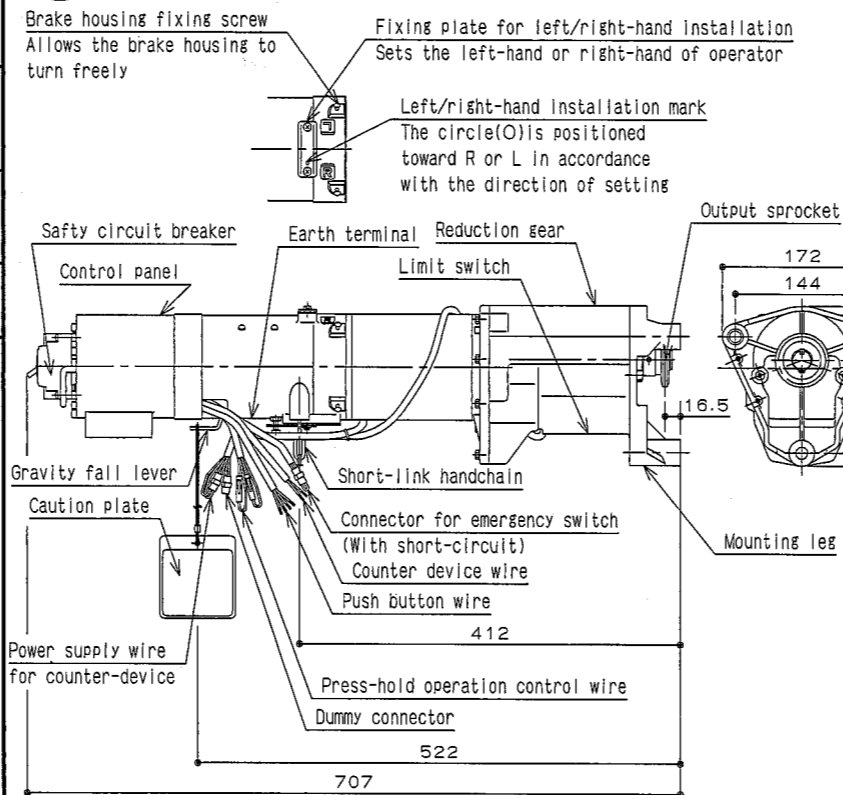

(3) Winding drum dimensions

Manufacture the winding drum in accordance with the undermentioned drawing.
If the rail depth is not 60 mm, change the winding drum dimensions (W+105) in accordance with the rail depth.

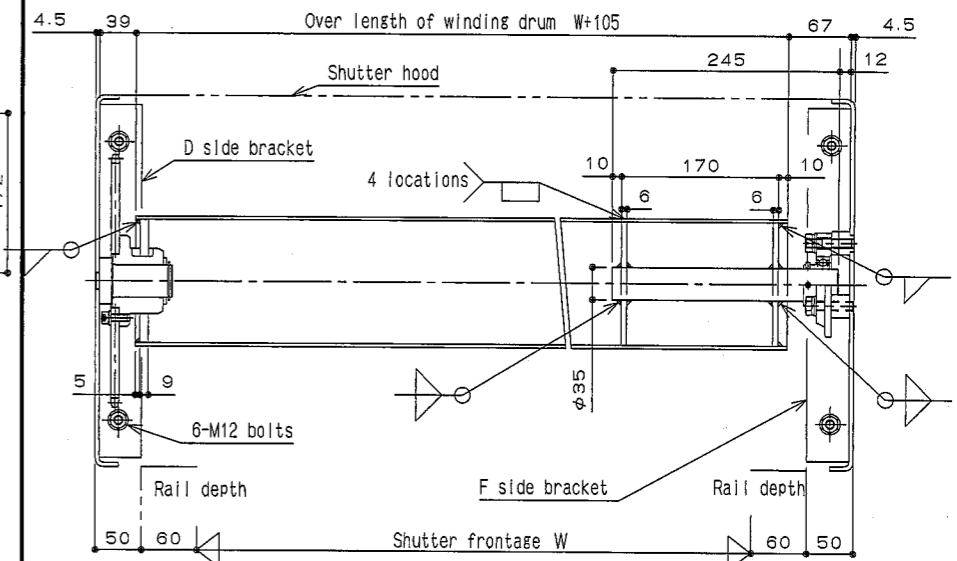

③ REFERENCE OF INSTALLATION

(1) Bracket (BT-25M) size

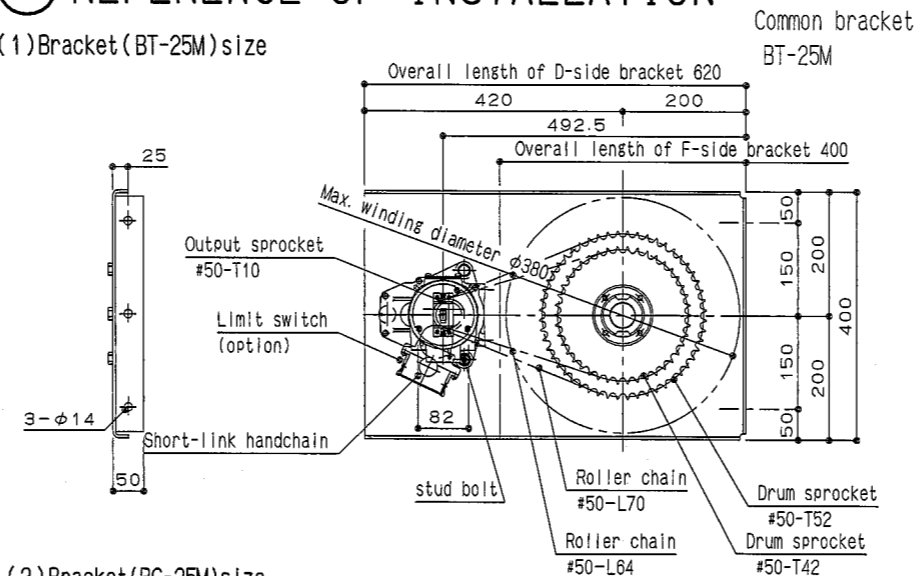

(2) Bracket (BC-25M) size

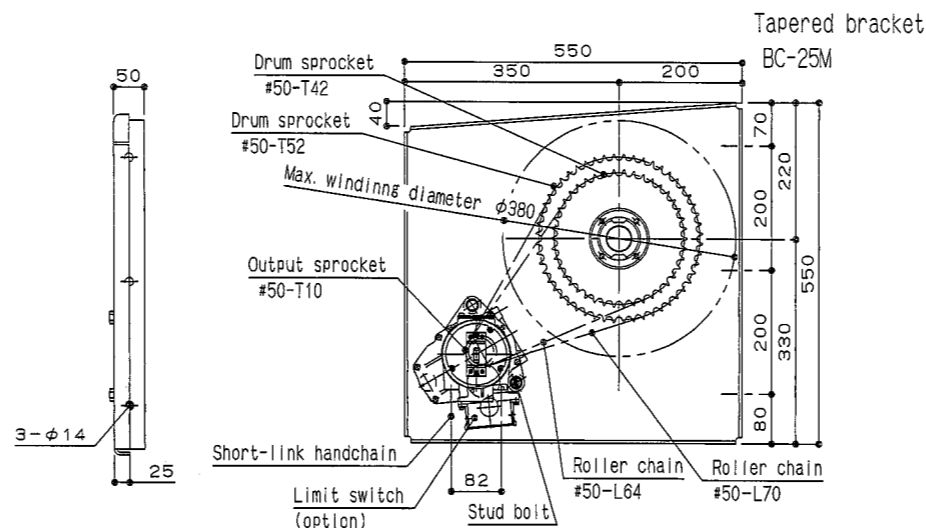

④ PACKAGE CONTENTS

The details of operator package, sprocket package and parts package are shown below. Be sure any damage did not occur on transit, or any shortage is not found in the package.

(1) Operator package

| | |
|---|---------|
| Power operator (incl. limit switch, built-on control panel, gravity fall cord with caution plate) | ... x 1 |
| Hexagon head bolts [spring washers, plain washers] (M10x75) | ... x 2 |
| Stud bolt [hexagon nut, spring washer, plain washer] (M10x85) | ... x 1 |
| Operation Manual | ... x 1 |

(2) Bracket package

| | |
|---|---------|
| D side bracket (incl. drum sprocket T42 or T52) | ... x 1 |
| F side bracket | ... x 1 |
| Parts box | ... x 1 |
| · roller chain #50-L64 (for T42) | ... x 1 |
| · roller chain #50-L70 (for T52) | ... x 1 |
| · flange unit | ... x 1 |
| · hexagon head bolts [spring washers, plain washers] (M10x45) | ... x 2 |
| · stud bolt [hexagon nut, spring washer, plain washer] (M10x55) | ... x 1 |

(3) Parts package (4B or 5B)

| | |
|-----------------------|---------|
| Drum flange (t9.0) | ... x 1 |
| Drum shaft (φ35xL245) | ... x 1 |
| Round flange (t6.0) | ... x 2 |

⑤ INSTALLATION OF POWER OPERATOR

(1) BEFORE INSTALLATION OF POWER OPERATOR

Fix our exclusive brackets tightly, which have enough strength to support all weight, in a suitable position on the structural members.

▲WARNING

Brackets bear overall weight. If this installation is not strong, injury may result by damaged shutter.

Be sure to mount roller chain on teeth of drum sprocket before installing a winding drum.

▲CAUTION

It is unable to set roller chain after installing the winding drum because of its endless (without joint).

(2) FIXING PLATE FOR LEFT/RIGHT-HAND SETTING

The operator is usable for either of left/right-hand setting by reversing the direction of fixing plate.

The fixing plate is usually set for right-hand setting at the factory, so be sure the setting in the site and reverse the fixing plate in case of left-hand setting.

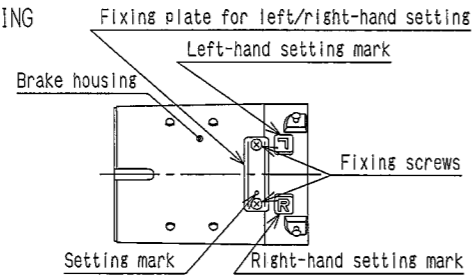

▲WARNING

The fixing plate should be reversed before the operator is set up.

If the fixing plate is removed from the brake housing under the condition that the operator is loaded, the shutter may fall by its gravity without effective braking, or an injury may result by the removed fixing plate.

(3) BRAKE HOUSING

When mounting the operator on the bracket, loosen 4 brake housing fixing screws before mounting and turn the angle of brake housing in order to enable the short-link handchain to be pulled downward.

After adjusting the position of brake housing, press it by hand from behind to tighten up the brake housing fixing screws so that there be no gap between the motor rear flange and the brake housing. For lightly working, pull the gravity fall lever when pressing the brake housing. And also tighten up 2 fixing screws in order along each diagonal line.

▲WARNING

The angle of brake housing should be adjusted before the operator is set up.

If it is adjusted under the condition that the operator is loaded, the brake housing may turn by the load, or an injury may result when the shutter falls by its own gravity.

▲CAUTION

Make sure without fail there be no gap between the motor rear flange and the brake housing.

If there be any gap, the brake performance may be decreased, then an injury may result when the shutter falls by its own gravity.

(4) INSTALLATION OF POWER OPERATOR

Install power operator in the following procedure.

- Mount roller chain on the output sprocket of power operator.
- Mount a stud bolt packed into the operator package on a specified position of bracket and pass the stud bolt through the one mounting leg of operator. (refer to ③ REFERENCE OF INSTALLATION)
- Turn the operator centering around the axle stud bolt and fix the other two legs with attached hexagon bolts.
- Make fine-adjustment so that roller chain has approximately 5 mm slack. Securely tighten up hexagon bolts and nuts after the adjustment.
- Remove wire from bound short-link handchain to enable manual operation.

(5) CHECK

Make sure of the following matters after finally setting up the operator.

- Roller chain is mounted from output sprocket to drum sprocket.
- 3 hexagon bolts are securely tightened to fix the operator.
- When pulling short-link handchain being outside against slats, sprocket and winding drum rotate toward roll-up direction.

▲WARNING

Make sure the above matters after finally setting up the operator, and any abnormality should be correct.

If the shutter is used without the above checking or with any abnormality, it may result in falling down and serious accident.

⑥ WIRING

▲WARNING

At electric work, to avoid fire, electrical shock or abnormal operation, be sure to keep the following matters.

- Only qualified person shall do electric work.
- Electric work shall be done based on an internal wiring regulation of an electrical equipment engineering standard or the like in each region.
- For 110V power source, be sure to discriminate between the voltage side and ground side for working.
- Disconnect power supply before electric work.
- All leads shall be connected securely.
- Ground leads from the earth terminal on bottom of the brake housing.

(1) CONNECTION DIAGRAM

This connection diagram shows a case that Push button switch with built-in counter (PBW series) is used with.

The connection depends on the right-hand or left-hand installation of operator. For right-hand setting, connect the wire as the figure shown below.

For left-hand setting, reverse the wire for OPEN(WHITE) and CLOSE(BLACK) of push button switch each other.

And reverse the connector for BLACK-BLACK side and WHITE-WHITE side of power supply wire for counter-device each other.

(Put the connector of WHITE-WHITE side into BLACK-BLACK side.)

· For press-hold operation to descend.

Right-hand setting: Pull out 1P-connector of JD1(BLACK)·JD2(BLACK).

Left-hand setting: Pull out 1P-connector of JU1(WHITE)·JU2(WHITE).

· For connecting emergency switch.

Pull out L5-L6 short-circuit connector, and connect to L5 L6

· Do not connect the connection wire(Yellow & Brown)for counter with any other counter except the one we specified.

· If Push button switch (PB series) is used, be sure to insulate the connection wire (Yellow & Brown) for counter with tapes.

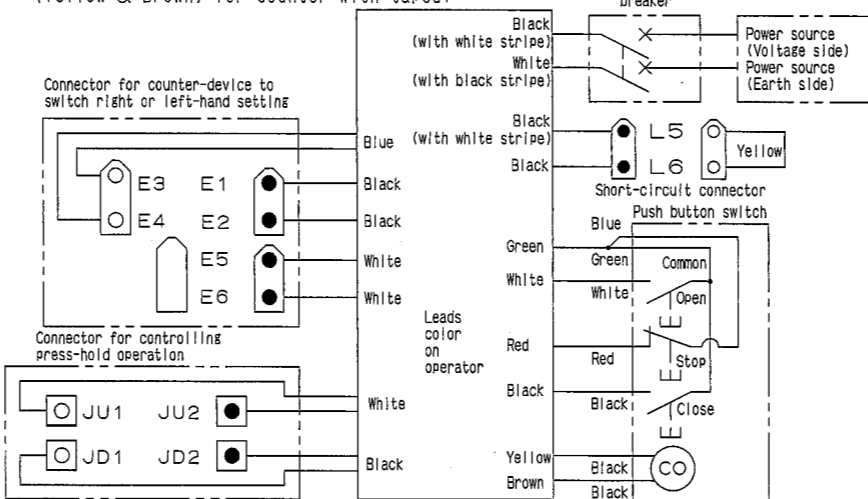

⑦ ADJUSTMENT OF LIMIT SWITCH

Open the limit cover located on the bottom of the gear case, and two set-levers will be found. (Refer to Fig.1)

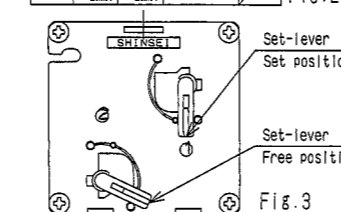
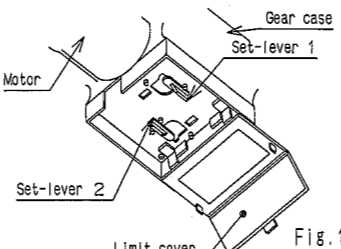

(1) The set-levers for upper/lower limit are reserved depending on right-hand or left-hand installation. Make sure of the installation (Refer to Fig.2)

(2) Place the set-levers ① and ② in the free position (Refer to Fig.3)

(3) In case of the right-hand installation, open the shutter up to the upper limit position under the condition of (2) and stop it. Turn the set-lever ① to the set position (Fig.1), and the upper limit is adjusted. Close the shutter up to the lower limit position and stop it. Turn the set-lever ② to the set position, and the lower limit is adjusted.

Note: Do not move the set-levers when the shutter is running.

(4) In case of the left-hand installation, the lower limit is adjusted with the set-lever ① and the upper limit is adjusted with the set-lever ②

(5) After the adjustment, be sure that the stop position is correctly set by the limit switch. If the stop position is incorrect, adjust it again.

(6) After complete adjustment, make sure to put on the limit cover.

⑧ OPERATION

▲WARNING

Be sure there is no obstacle on the closing line, in advance of operation.

Do not enter on the closing line during shutter is running.

Do not be away from the push button switch until open/close operation finishes.

Be sure the shutter finally stops, because moving shutter can injure people.

(1) POWER OPERATION (WITH PUSH BUTTON SWITCHES)

For opening shutter, press 'OPEN' (or '開') button and for closing shutter, press 'CLOSE' (or '閉') button until the shutter begins to move.

The shutter automatically stops at the fully opening/closing position.

For stopping shutter at a desired position, press 'STOP' (or '停') button, and it stops at the position.

For reversing a moving shutter, once press 'STOP' (or '停') button, before pressing 'OPEN' (or '開') button or 'CLOSE' (or '閉') button.

Reverse operation is rejected while shutter is moving.

(2) MANUAL OPERATION

This operation is used for opening shutter in the case of power failure or the like.

· Open shutter hood to hang short-link handchain. Slowly pull short-link handchain being outside against slats, and shutter will open in proportion to pulling.

(Required force for operation is approximately 50N. Shutter will rise up to approximately 4 mm by handchain operation for 1 m. This value will change depending on the number of drum sprocket teeth.)

(3) GRAVITY FALL OPERATION

This operation is used for closing shutter in the case of power failure or the like.

· Open shutter hood and pull the gravity fall cord, and shutter will close by its own gravity.

For stopping shutter, release the gravity fall cord.

(Required force for operation is approximately 50N. The shutter speed falling via gravity is approximately 1.5 times of the closing speed with power, because rate of descent is controlled by a speed governor.)

⑨ CONFIRMATION

Confirm the next items after the installation is completed.

1. A shutter should open and close by the operation of the push button switch.
2. A counter should count once per one operation for closing shutter.
3. A shutter should stop at each positions of the upper and lower limit where it was set up with a limit switch.
4. A shutter should stop by hauling the handchain or turning the crankhandle.
5. A shutter shouldn't work with the powered motor during the operation of the emergency switch.
6. A shutter should move down when the gravity fall cord is pulled.

⑩ INSPECTION

For safely using, a periodic inspection is required.

The inspection must be carried out at the time when the operator reached to either the following number of times or period.

· 1000 OPEN/CLOSE · 6 MONTHS

If you have any question, please contact the shutter manufacturer.

FOR CONTACT

SHINSEI SEIKI CO., LTD.