

INSTRUCTION MANUAL

<OM-A190G-4ACU> MODEL SSA-1900G(Handchain type)
THREE-PHASE 200V~220V 380~480V

This instruction manual describes only matters related to the operator.
As for handling in a whole shutter system please refer to instructions given
by the shutter manufacturer.

① ATTENTION OF SECURITY

There are "WARNING" and "CAUTION" to be separated by degree of harm and damage.

⚠ WARNING: If the system is wrongly set up or handled, death or serious injury may result.

- (1) In positioning the motor-driven operator properly, carefully read the catalogue.
- (2) The shutter operator is specifically designed for motor-driven shutters.
Never use the shutter operator for any other applications.
- (3) Setting up the shutter operator includes works to be done by a well-skilled, qualified electrician. Only such qualified person shall install the shutter operator.
Otherwise the operator may not work normally, and the shutter may damage, then an injury may result
- (4) Use brackets which have enough strength to support shutter weight and fix them in a position on structural members, referring to the shutter layout (installation drawing).
As the brackets bear all shutter weight, an injury may result by damaged shutter if it is not tightly fixed.
- (5) Fix the bed and the shutter operator in a position on the structural members, referring to the shutter layout (installation drawing).
Otherwise the operator may not work normally, and an injury may result by damaged shutter as the case maybe.
- (6) Install the shutter operator in a place not exposed to rain and any other water.
Otherwise a fire or an electrical shock may result.
- (7) Be sure to ground the shutter operator.
Otherwise a fire or an electrical shock may result.
- (8) Do not disassemble nor tamper with the shutter operator. Nor attach any extra components than our specified options.
Otherwise an injury may result by abnormal operation.
- (9) Before opening and closing the shutter, make sure there is nobody and no obstacle around.

Be sure to instruct the person in charge of the shutter operator to keep this is in mind.

- (10) Choose key-locked pushbutton switches.
Otherwise an injury may result by being caught in the shutter if any other person being not in charge, e.g. a child, operates.

⚠ CAUTION: If the system is wrongly set up or handled, personal injury or property damage may result.

- (1) Be sure to keep the supply voltage within the shutter operator's specified range.
Otherwise the operator may damage, and then it may cause a fire or an electrical shock.
- (2) Make sure the shutter's weight and size are below the door's applicable ratings.
Otherwise the operator may not work normally, and the shutter may damage, then an injury may result.
- (3) Before using the manual short-link handchain, make sure the shutter is not moving. Never use the pushbutton switches.

Be sure to instruct the person in charge of the shutter operator to keep this is in mind.

Otherwise the manual short-link handchain will be pulled into the operator, then the operator may result in damage.

- (4) Before using the controlled descent lever, make sure the shutter is not moving. Never use the pushbutton switches.

Be sure to instruct the person in charge of the shutter operator to keep this is in mind.

- Otherwise the operator may not work normally, then the shutter may damage.
- (5) Make proper limit switch settings. And be sure to check the stop position.
- (6) Install an operator so that the operative direction of solenoid become downward.
*Otherwise the operator may not work normally.
- (7) Place order for operators after confirming the installation of right-hand or left-hand.
*It is unable to change the specification at the site.
- (8) Inspect the shutter operator periodically. If anything unusual is found, repair or replace. For periodic checks, keep the number of times or period for inspection given in the INSPECTION clause on this instruction manual.

② PARTS DETAILS OF OPERATOR

(1) SSA-1900G handchain type (For right-hand installation)

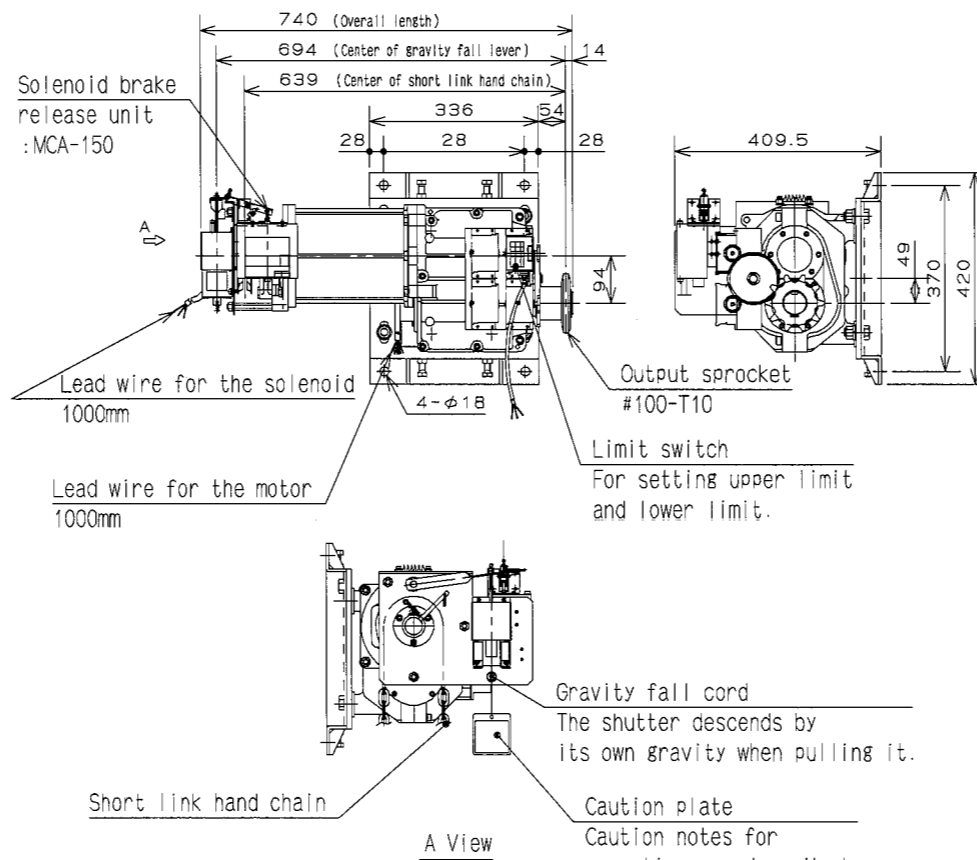

(2) Control panel

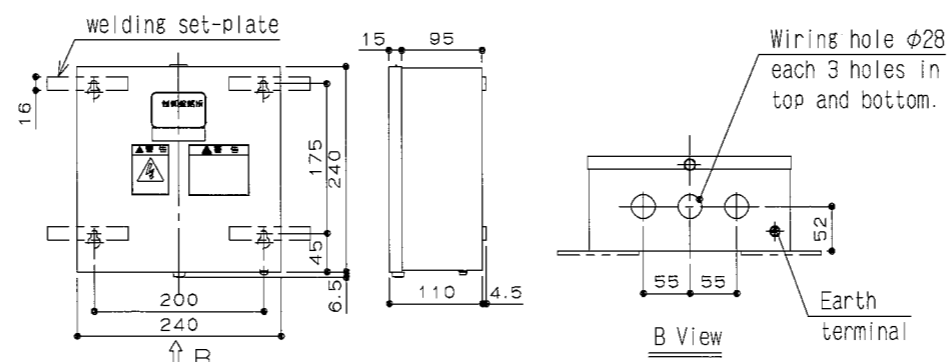

③ REFERENCE OF INSTALLATION

(1) Winding drum dimensions

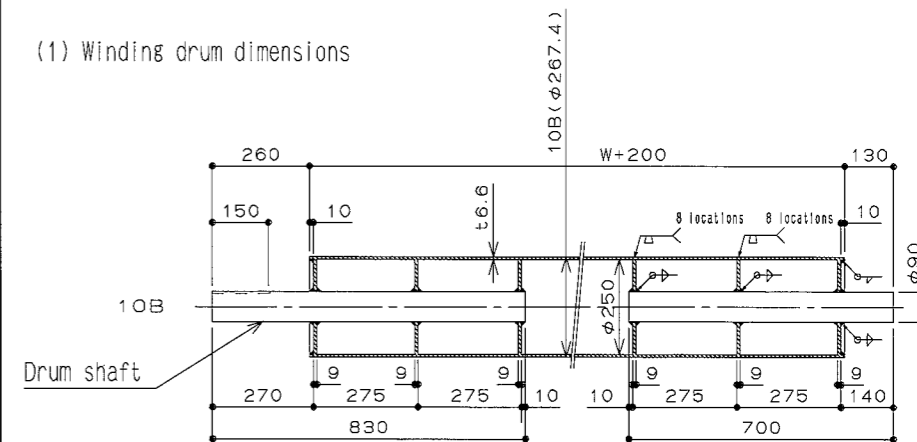

(2) Setting layout

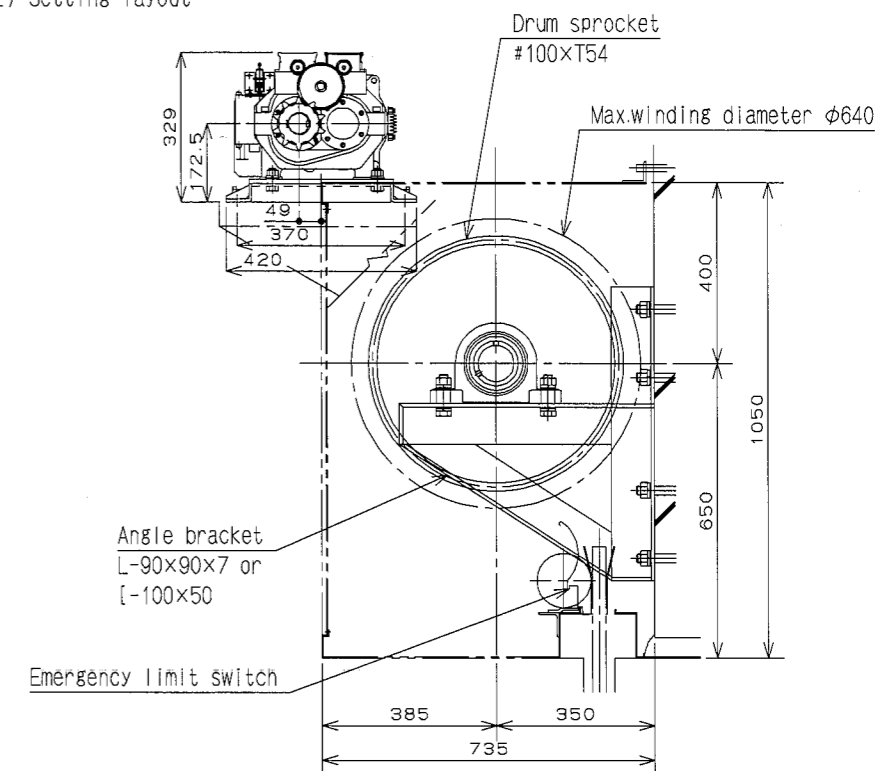

④ PACKAGE CONTENTS

The details of operator package and sprocket package are shown below.
Be sure any damage did not occur on transit, or any shortage is not found in the package.

- | | |
|--|-----------|
| (1) Operator package | × 1 |
| · Power operator (incl. bed, short link handchain, gravity fall cord with caution plate) | × 1 |
| · Roller chain [#100-91 Links with joint link and offset link] | × 1 |
| (Parts package) | × 1 |
| · Limit switch [incl. setscrews] | × 1 |
| · Relay cable for limit switch | × 1 |
| · Emergency limit switch [incl. setscrews] | × 1 |
| · Shift-lever cord for short-link handchain | × 1 |
| · Instruction Manual | × 1 |
| (2) Control panel package | × 1 |
| · Control panel (incl. gromet, welding flat bar, setscrews) | × 1 |
| (3) Flange unit package | × 2 |
| · Flange unit | × 2 |
| (4) Sprocket package | × 1 |
| · Drum sprocket (#100W-T54) | × 1 |
| · Parallel key | × 1 |

⑤ INSTALLATION OF POWER OPERATOR

(1) BEFORE INSTALLATION OF POWER OPERATOR

Fix the angle brackets tightly, which have enough strength to support all weight, in a suitable position on the structural members.

▲ WARNING

If the angle brackets are not fixed tightly, an injury may result by damaged shutter because these bear a whole shutter weight.

Fix the drum sprocket in a suitable position on the drum shaft, referring to the shutter layout (installation drawing).

Fix the bed support in a suitable position on the structural members, referring to the shutter layout (installation drawing).

▲ CAUTION

If the fixed position was wrong, the operator may not work normally, and an injury may result by damaged shutter as the case maybe.

(2) INSTALLATION OF POWER OPERATOR

Install power operator in the following procedure.

1) In the installation, the brake housing is to be set on power operator so that the operative direction of solenoid faces downward.

At this time, tighten hexagon bolts firmly.

2) Mount power operator on the bed support and slightly tighten 4 hexagon nuts. When installing one body of power operator fixed on the bed support, slightly loose 4 hexagon nuts.

3) Mount roller chain on output sprocket and drum sprocket.

Cut off remaining roller chain with a chain cutter or the like.

Then adjust the operator position with the supplied tension bolt so that chain has approximately 2 % slack on center-to-center distance.

After completion of adjustment, tighten 4 hexagon nuts firmly.

*Connect roller chain securely

4) Mount the limit switch on power operator.

(3) CHECK

Make sure of the following matters after finally setting up the operator.

·Roller chain is mounted on output sprocket and drum sprocket, and each center can be aligned.

·And also a slack of roller chain is in the prescribed level, and roller chain is connected securely.

·Nuts are securely tightened with tension bolt and bolts in bed support.

·Hexagon bolts of brake housing are tightened firmly.

▲ WARNING

Make sure the above matters after finally setting up the operator, and any abnormality should be correct.

·If the shutter is used without the above checking or with any abnormality, it may result in falling down and serious accident.

⑥ WARNING

▲ WARNING

At electric work, to avoid fire, electrical shock or abnormal operation, be sure to keep the following matters.

○ Only qualified person shall do electric work.

○ Electric work shall be done based on an internal wiring regulation of an electrical equipment engineering standard or the like in each region.

○ Disconnect power supply before electric work.

○ All leads shall be connected securely.

○ Be sure of grounding work between control panel and operator using earth terminal of control panel. (Use earth terminal of brake case for three phase 200~220V and earth wire of motor for three phase 380~480V respectively.)

(1) CONNECTION DIAGRAM

The following figure shows connections for terminal board on the control panel.

·Directly connect power supply to Safety circuit breaker

·The figure shows the connection diagram for right-hand side set-up.

·In case of the left-hand side set-up, replace Red and Blue(or Red and Black) of the motor wires and Orange and Black of the limit switch wires.

·Anti-phase relay is incorporated into the control panel.

·If the motor does not run, reverse any two of the three power leads.

·When an emergency limit switch is not used, short-circuit with the attached lead between L1 and 1 on terminals.

·Each color is for lead wires in three phase 380~480V and the color in parentheses is for lead wires in three phase 200~220V.

·Please connect Solenoid after a check of power supply frequency without making a mistake in a lead color. Please be sure to insulate (tape) the lead which is not used.

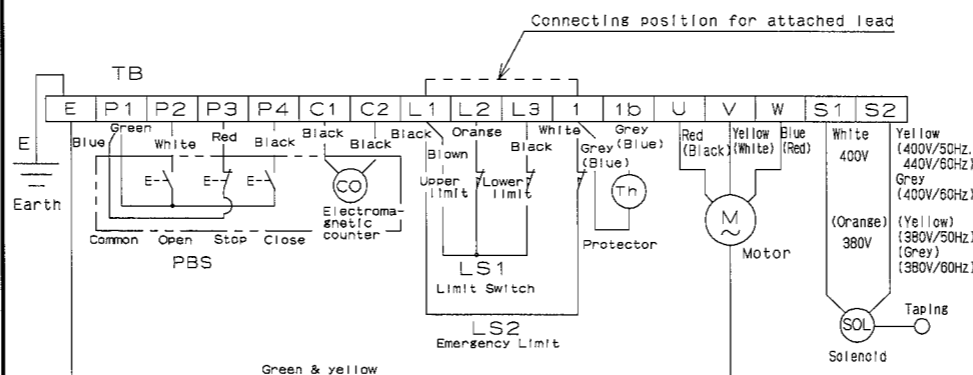

⑦ ADJUSTMENT OF LIMIT SWITCH

HOW TO SET THE LIMIT SWITCHES

In case of right-hand installation, the upper limit is set by set-lever ① and the lower limit is set by set-lever ②. In case of left-hand installation, set-lever ① is contrarily replaced with set-lever ②. (Refer to Fig.1)

(1) Lay down both set-levers ① and ② until they are locked (approx. 90°).

(2) In case of right-hand installation, first run shutter up to the required upper limit position under the condition of (1), then return set-lever ① (to be as Fig.2), and the upper limit position is completely set. Second return set-lever ②, and the required lower limit position can be set.

(3) In case of left-hand installation, the lower limit position is set by set-lever ① and the upper limit position is set by set-lever ②.

設定レバー LEVER	右勝手 RIGHT-HAND	左勝手 LEFT-HAND	接点構成 CONTACT COMPONENT
①	上限 UPPER LIMIT	下限 LOWER LIMIT	茶 Brown 橙 Orange
②	下限 LOWER LIMIT	上限 UPPER LIMIT	黒 Black

Fig.1

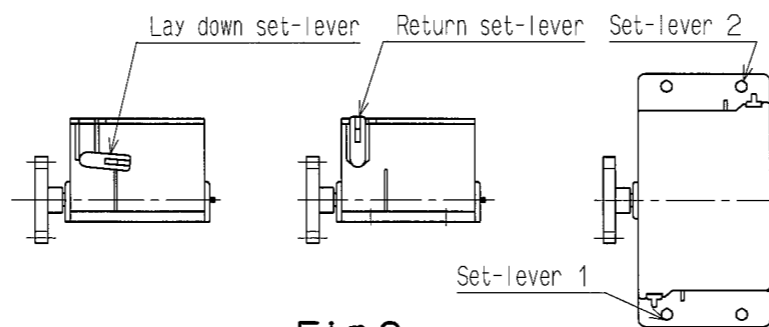

Fig.2

⑧ OPERATION

▲ WARNING

Be sure there is no obstacle on the closing line in advance of operation.
Do not enter on the closing line while shutter is running.
Do not be away from the pushbutton switch until open/close operation finishes.
Be sure the shutter finally stops because moving shutter can injure people.

(1) POWER OPERATION (WITH PUSHBUTTON SWITCHES)

For opening shutter, press 'OPEN' (or '開') button and for closing shutter, press 'CLOSE' (or '閉') button until the shutter begins to move.

The shutter automatically stops at the fully opening/closing position.

For stopping shutter at a desired position, press 'STOP' (or '停') button, and it stops at the position.

For reversing a moving shutter, once press 'STOP' (or '停') button before pressing 'OPEN' (or '開') button or 'CLOSE' (or '閉') button.

Reverse operation is rejected while shutter is moving.

(2) MANUAL OPERATION

This is used for opening shutter in case of power failure or the like.

Open shutter hood to hang short-link handchain.

Haul shift lever cord to engage chainwheel with brake drum and pull handchain towards either side in order to make sure of opening shutter, then fix shift lever cord tightening.

Fix controlled descent cord tightening without losing handchain. At this time, handchain should be tightly maintained.

Repeatedly haul handchain to open shutter as controlled descent cord was pulled.

*Make sure of the direction of handchain for raising shutter up because it depends on the installation.

When finishing handchain operation, release controlled descent cord first, making sure that handchain is maintained, and after that release shift lever cord.

(Required force for operation is 200N. Shutter will rise to approximately 10mm by handchain operation for 1 m. This value will change depending on the number of drum sprocket teeth.)

(3) CONTROLLED DESCENT OPERATION

This operation is used for closing shutter in case of power failure or the like.

·Open shutter hood and pull controlled descent cord, and shutter will descend by its own gravity.

To stop shutter, release controlled descent cord.

(Required force for operation is approximately 40N. The shutter speed falling via gravity is approximately 1.5 times of the closing speed with power because rate of descent is controlled by a speed governor.)

⑨ INSPECTION

For safely using, a periodic inspection is required.

The inspection must be carried out at the time when the operator reached to either the following number of times or period.

· 1000 OPEN/CLOSE · 6 MONTHS

If you have any question, please contact the shutter manufacturer.

FOR CONTACT

BX Shinsei Seiki Co., Ltd.